

ADDENDUM#1

(MARCH 23, 2022)

Bid NO: 2022-03-07

TOWNSHIP OF PISCATAWAY: “2022-STERLING VILLAGE PARKING LOT REHABILITATION”

Bidder’s Electronic Question Due Date: MARCH 18, 2022 @12NOON

Official Addenda Process: MARCH 23, 2022.

Purchasing@piscatawaynj.org

PRE-BID Conference / Site Visit Date: MARCH 15, 2022 @2PM @ 1 STERLING VILLAGE DRIVE, PISCATAWAY NJ 088854

Bid Submission Due Date: THURSDAY MARCH 31, 2022 @2PM

Bidders must call the purchasing office at 732-562-2321 to drop off the sealed bid. The Municipal building is closed to the public due to the Covid-19.

PLEASE, DROP OFF YOUR SEALED BID BY OR BEFORE 12NOON ON 3/31/2022.

BIDS WILL BE OPENED VIA ZOOM @2PM

Bid Opening via ZOOM: Instructions below:

During the Covid-19 pandemic, while the statewide “State of Emergency” declaration is still in effect in according with Executive Order 107 all proposal packets will only be read and opened electronically “BROADCAST LIVE” via ZOOM Bid opening. The Municipal building is closed due to the Covid-19 restrictions. Once the bid opening is concluded bidders must call the Purchasing Agent @ 732-562-2321 to set an appointment if bidders wishes to review any of the bids.

All bids shall be kept sealed , and will be received and publicly opened on the proposal opening date and time in the Township Council Chambers using Virtual teleconferencing which can be access by logging in to zoom in the following manner:

Join Zoom Meeting

Piscataway Purchasing is inviting you to a scheduled Zoom meeting.

Topic: 2022-STERLING VILLAGE PARKING LOT REHABILITATION

Time: Mar 31, 2022 02:00 PM Eastern Time (US and Canada)

Meeting ID: 815 1802 5256

Passcode: 008826

QUESTION

ANSWERS

1. Per Local Public Contracts Law, "Any bid specification prepared pursuant to this section that includes the use of 1,000 or more tons of hot mix asphalt, shall include a pay item for any asphalt price adjustment reflecting changes in the cost of asphalt cement." The projected amount of asphalt for the installation of parking lot surface, HMA path, and base course repairs exceeds this threshold. Accordingly, the township should provide an addendum to include an allowance for asphalt price adjustment.

An allowance of \$4,000 has been added for "Asphalt Price Adjustment" as part of Addendum #1. See Line item #6 of the "Base Bid Tabulation" table on the revised Bid Proposal Form.

2. There is no detail or specification provided for the Hot Mix Asphalt Sidewalk, 5" thick. Can the township please provide a detail for this scope of work.

The requested detail has been added as part of Addendum #1. Refer to revised Drawing CSD-1 for "Hot Mix Asphalt Sidewalk" detail.

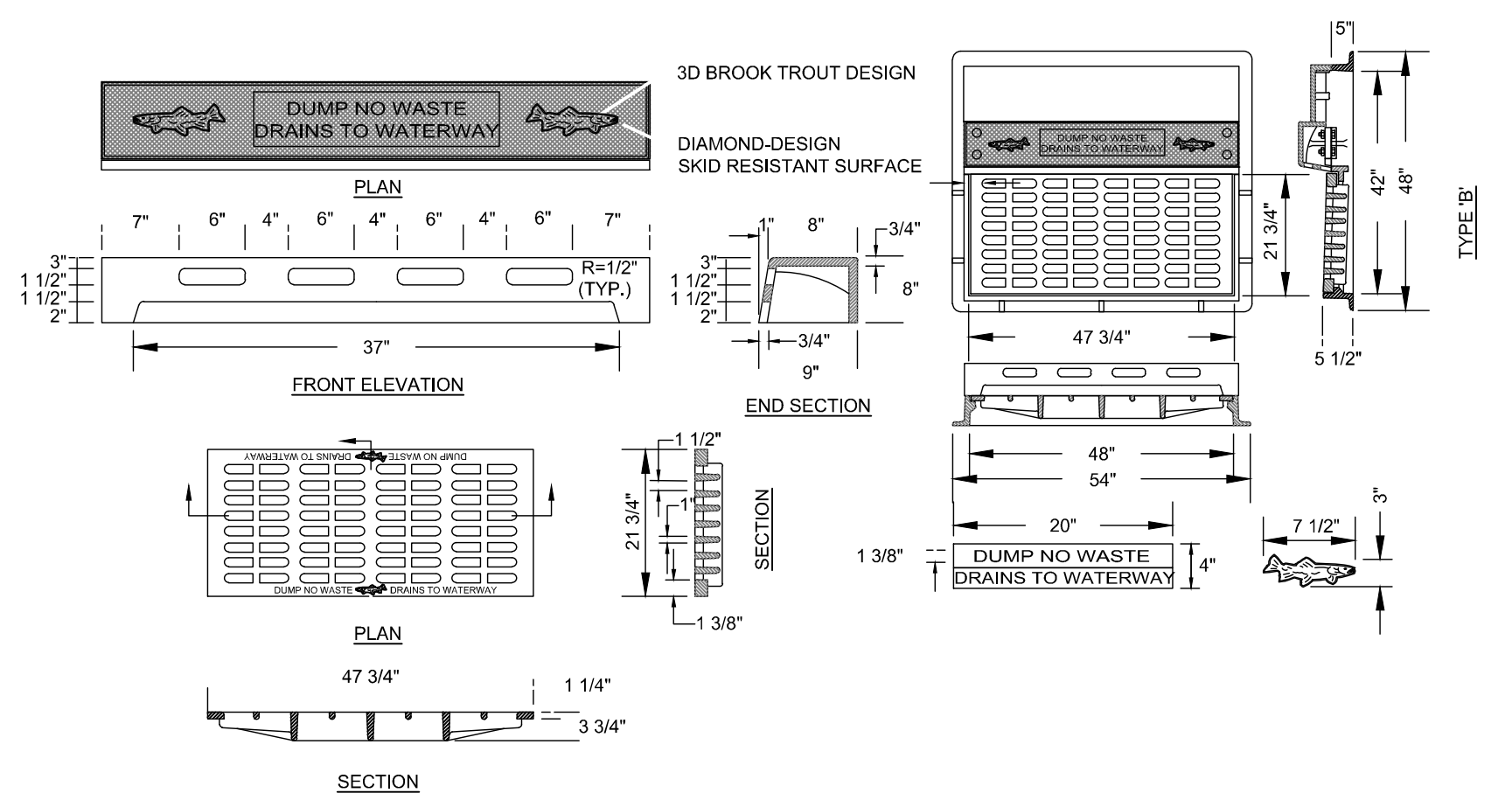

NOTES:
 1. BICYCLE SAFE GRATES SHALL BE PROVIDED ON ALL INLETS WITHIN THE PROJECT LIMITS. TYPE "B" INLET GRATES SHALL BE CAMPBELL FOUNDRY PATTERN NO. 2618 OR APPROVED EQUIVALENT. TYPE "C" INLET GRATES SHALL BE CAMPBELL FOUNDRY PATTERN NO. 3425 OR APPROVED EQUIVALENT.
 2. CURB PIECE SHALL BE TYPE "N-ECO", FOR 6" DR OR 8" CURB PIECES.

NJDEP APPROVED INLET CASTINGS
 NOT TO SCALE

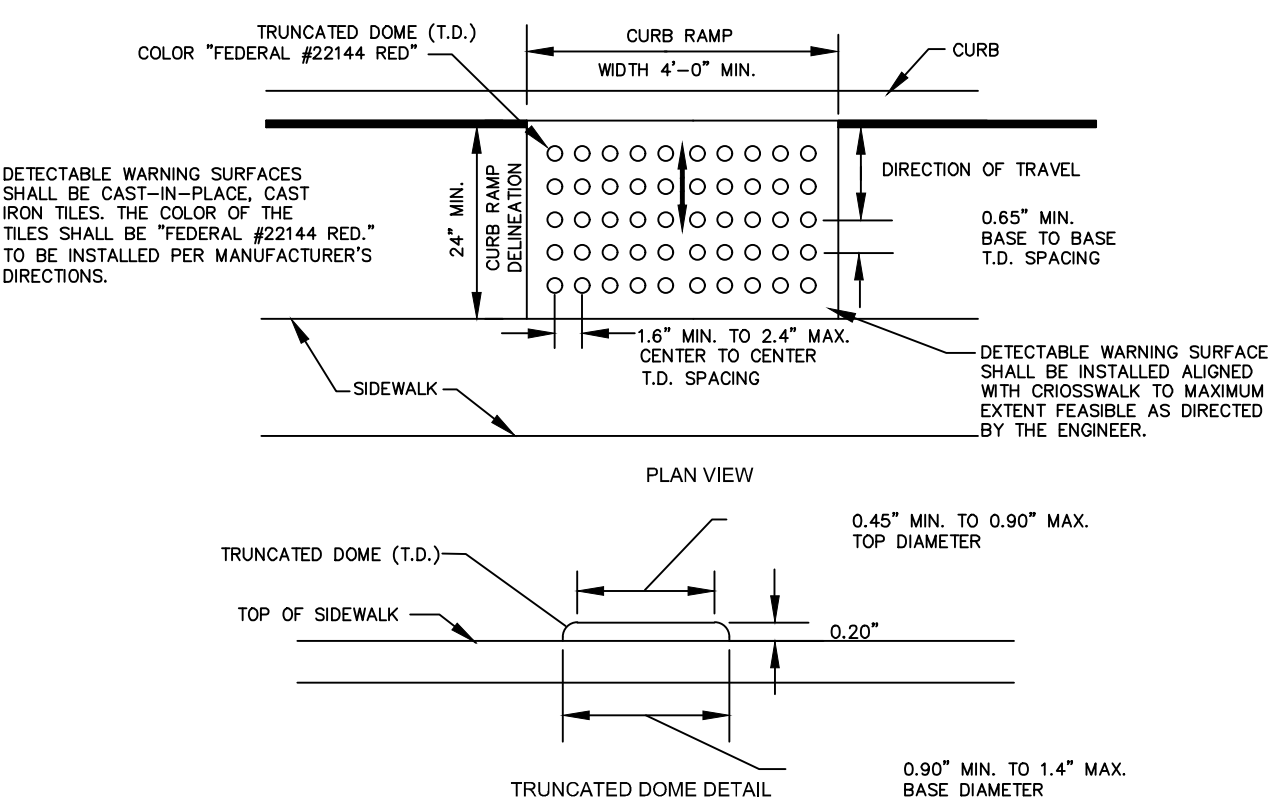

DETECTABLE WARNING SURFACE DETAIL
 NOT TO SCALE

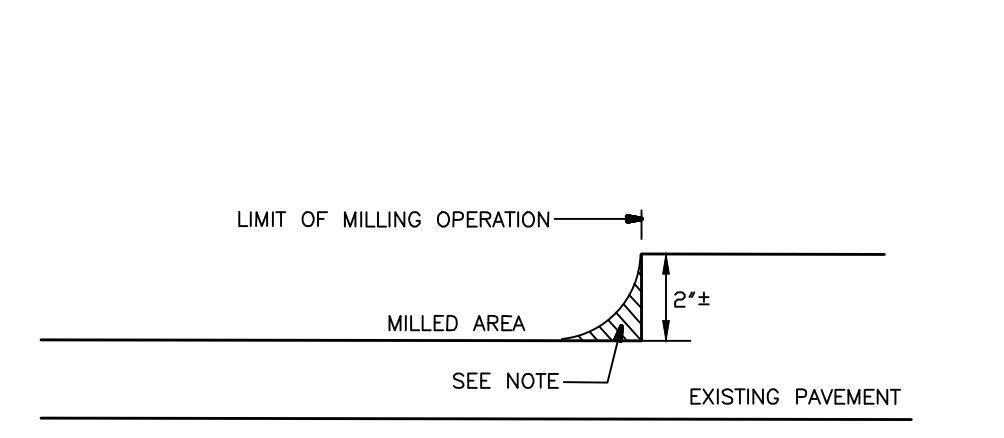
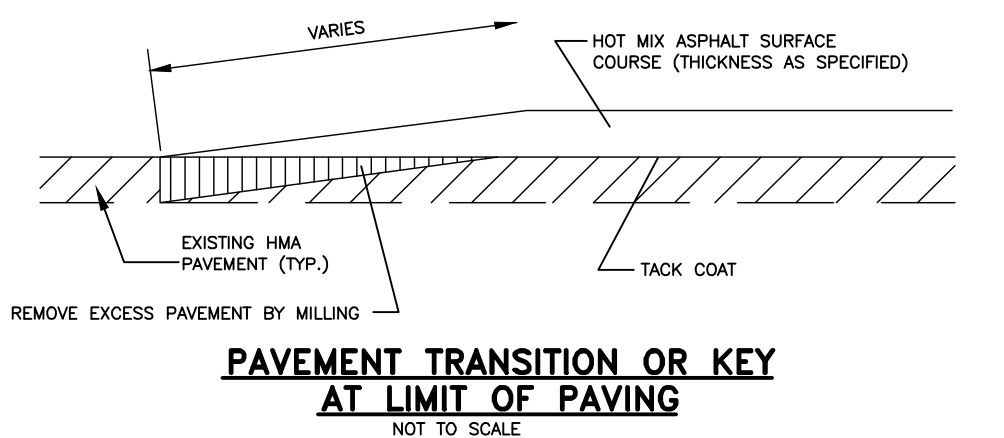

BITUMINOUS MATERIAL LEFT BY THE MILLING DRAWING RADIUS AT THE LIMIT OF THE MILLING OPERATION SHALL BE REMOVED. SAWING OR TRANSVERSE MILLING SHALL BE USED TO INSURE THAT THE EXPOSED FACE IS CLEAN AND VERTICAL. THIS END TREATMENT IS NOT REQUIRED AT TEMPORARY LIMITS OF MILLING (I.E. END OF WORKDAY). IT IS REQUIRED IN ALL INSTANCES AT WHICH THE COMPLETED MILLING OPERATION IS PROPOSED TO MATCH EXISTING PAVEMENT GRADES.

END TREATMENT FOR MILLING OPERATIONS
 N.T.S.

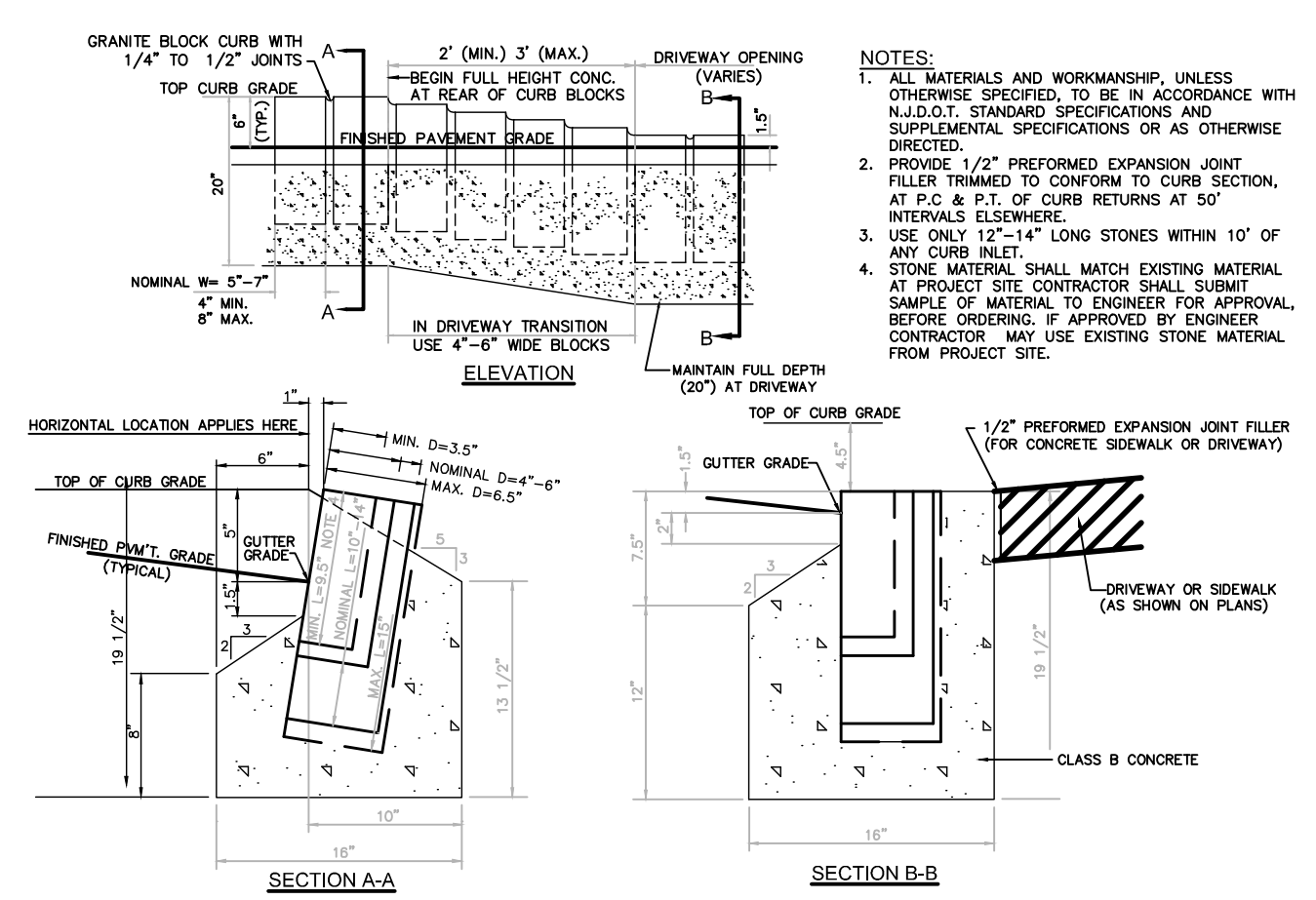

GRANITE BLOCK CURB-ALTERNATE
 N.T.S.

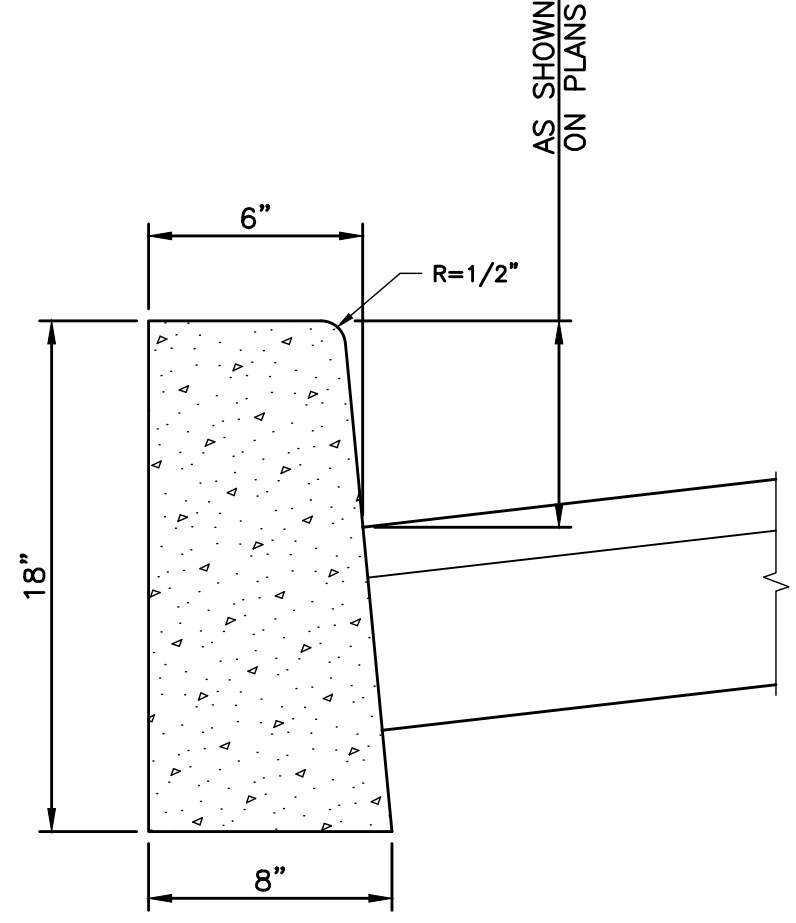

6\"X18\" CONCRETE VERTICAL CURB
 N.T.S.

CONSTRUCTION NOTES:
 1. ALL CONCRETE SHALL BE N.J.D.O.T. CLASS "B". PROVIDE CURB FACE AS INDICATED ON PLANS.
 2. PROVIDE PREFORMED BITUMINOUS FIBER EXPANSION JOINTS, 1/2" THICK AT 20'-0" (MAXIMUM) INTERVALS.
 3. PROVIDE DUMMY JOINTS (FORMED) BETWEEN EXPANSION JOINTS.

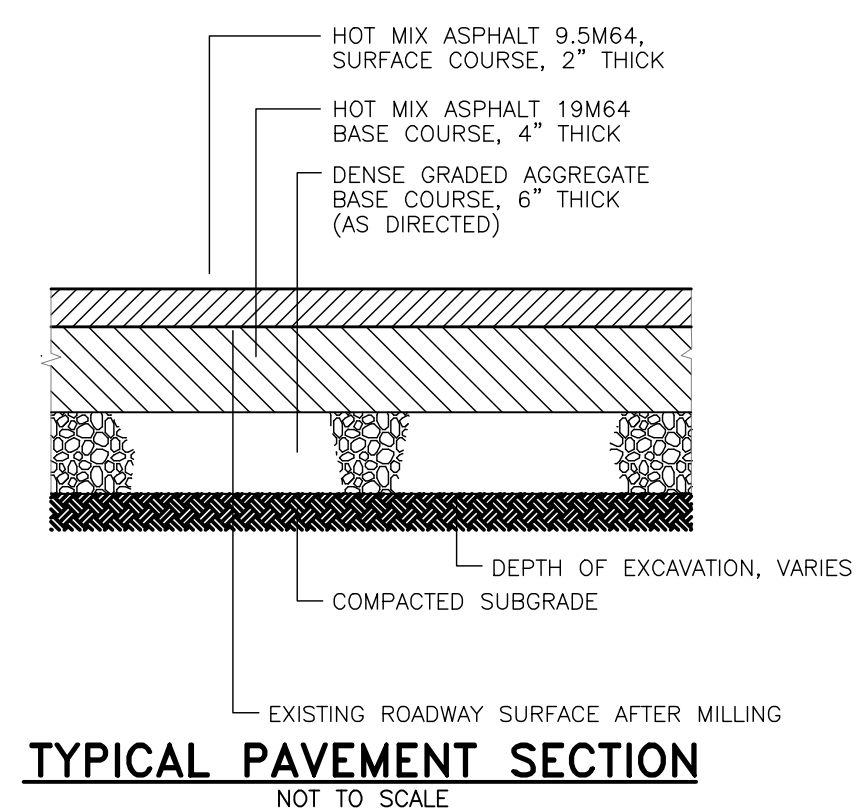

TYPICAL PAVEMENT SECTION
 NOT TO SCALE

NOTES:
 1. ANY EXCAVATION BELOW DESIRED GRADE DUE TO OVER EXCAVATION OR UNSUITABLE SOIL CONDITIONS SHALL BE BACKFILLED WITH DENSE GRADED AGGREGATE. ALL SUBGRADES SHALL BE REVIEWED AND APPROVED BY THE ENGINEER PRIOR TO INSTALLING PAVEMENT REPAIR.
 2. CONTRACTOR IS TO SUBMIT A PAVING PLAN TO THE ENGINEER PRIOR TO CONSTRUCTION.

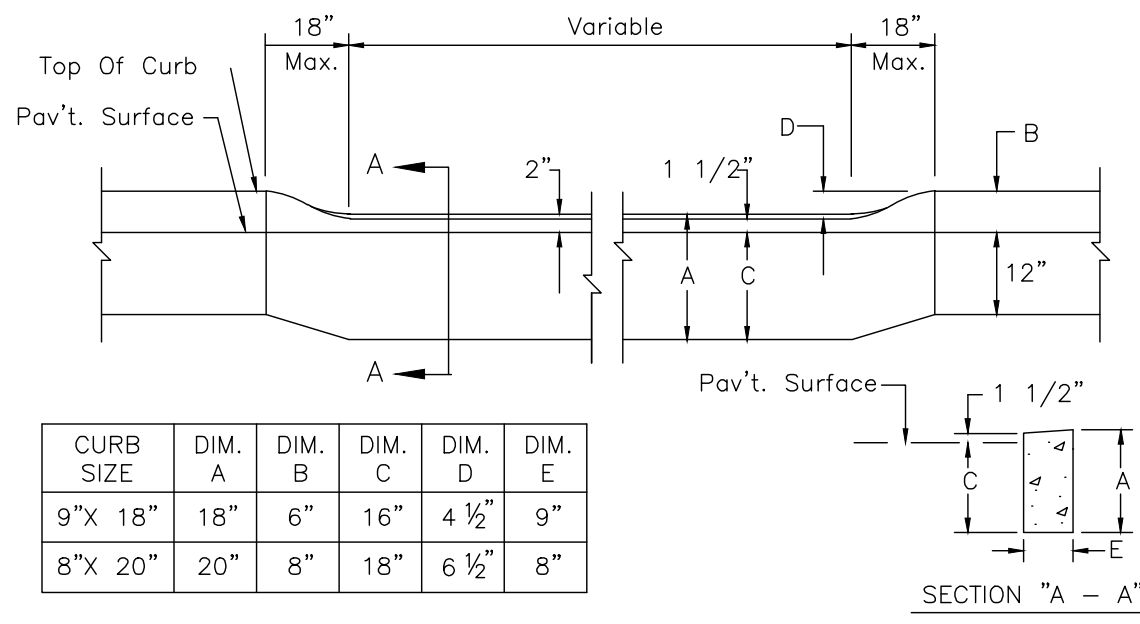

METHOD OF DEPRESSING CURB AT DRIVEWAYS
 NOT TO SCALE

CURB SIZE	DIM. A	DIM. B	DIM. C	DIM. D	DIM. E
9"X 18"	18"	6"	16"	4 1/2"	9"
8"X 20"	20"	8"	18"	6 1/2"	8"

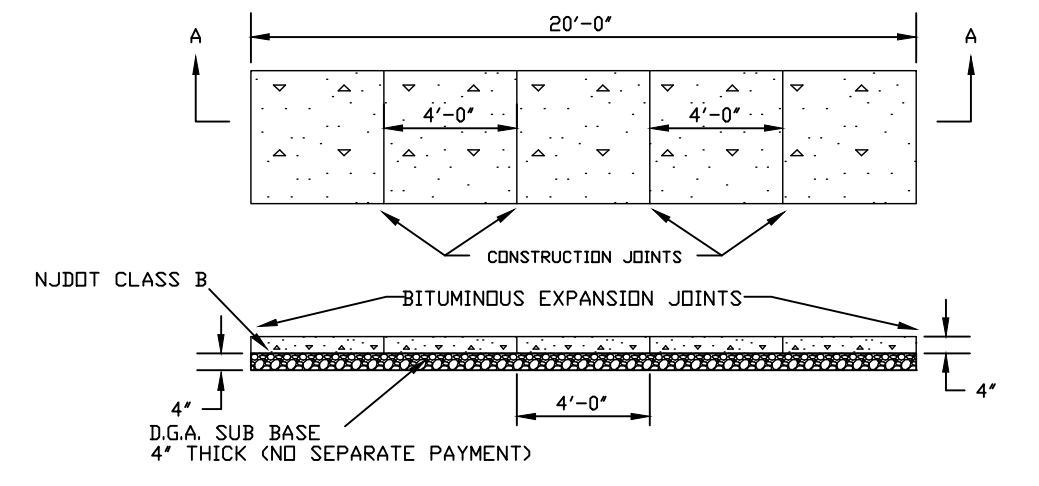

CONCRETE SIDEWALK
 N.T.S.

CONSTRUCTION NOTES:
 1. A PREFORMED, BITUMINOUS EXPANSION JOINT 1/2" THICK, 4" WIDE, AND EXTENDING THE FULL WIDTH OF THE WALK, UNBROKEN, SHALL BE INSTALLED EVERY TWENTY (20) FEET.
 2. CONSTRUCTION JOINTS SHALL BE INSTALLED EVERY FOUR (4) FEET THE FULL WALK WIDTH.
 3. THERE SHALL BE A FLOAT FINISH WITH THE EDGES FINISHED WITH A SUITABLE TOOL.
 4. SUB BASE SHALL BE 4" THICK D.G.A. NO SEPARATE PAYMENT WILL BE PROVIDED.

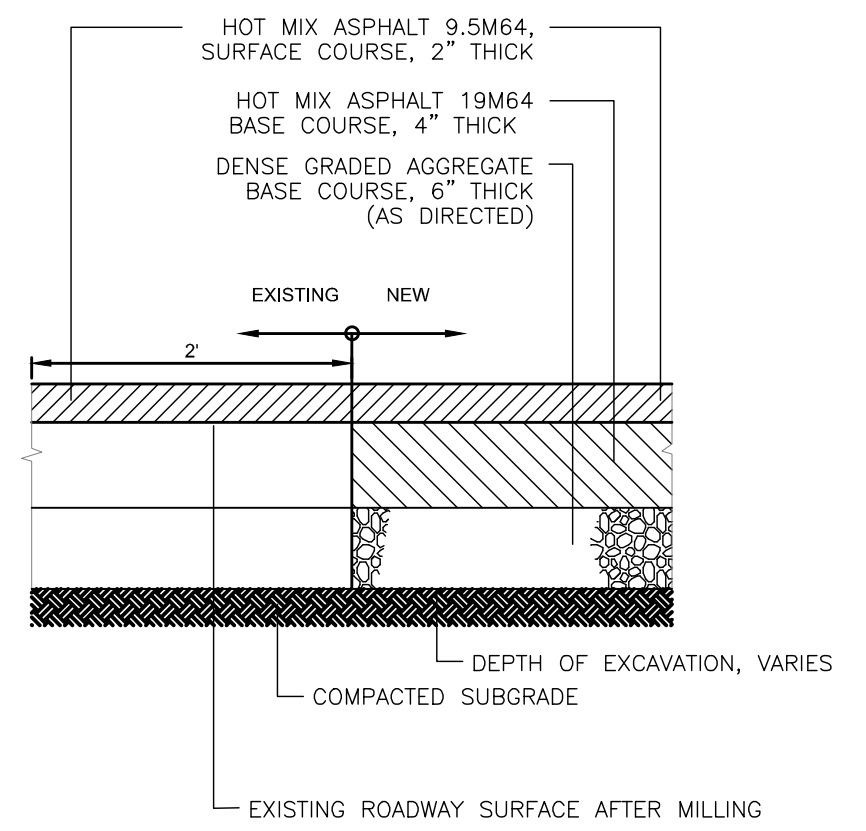

PAVEMENT TIE IN DETAIL
 NOT TO SCALE

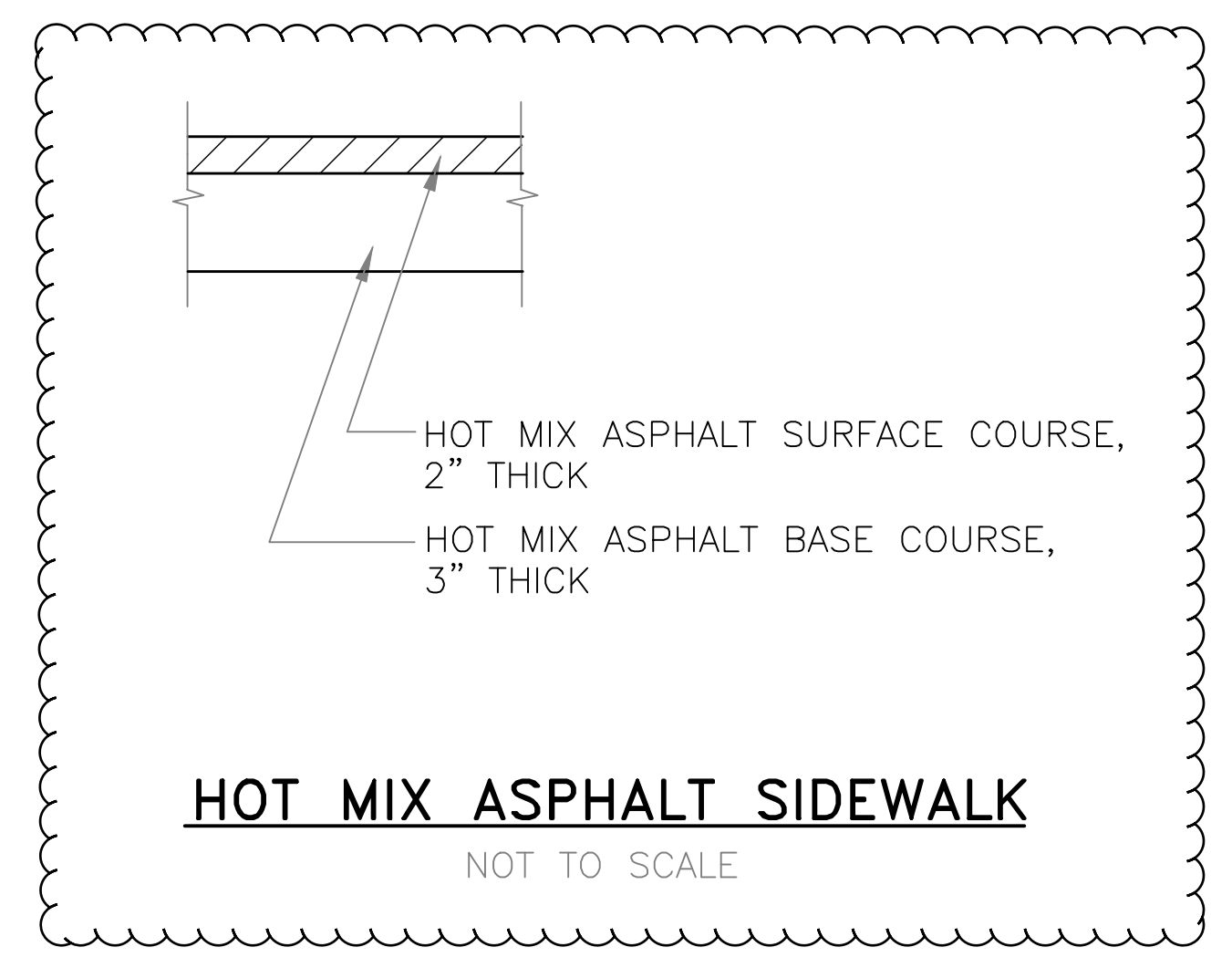

HOT MIX ASPHALT SIDEWALK
 NOT TO SCALE

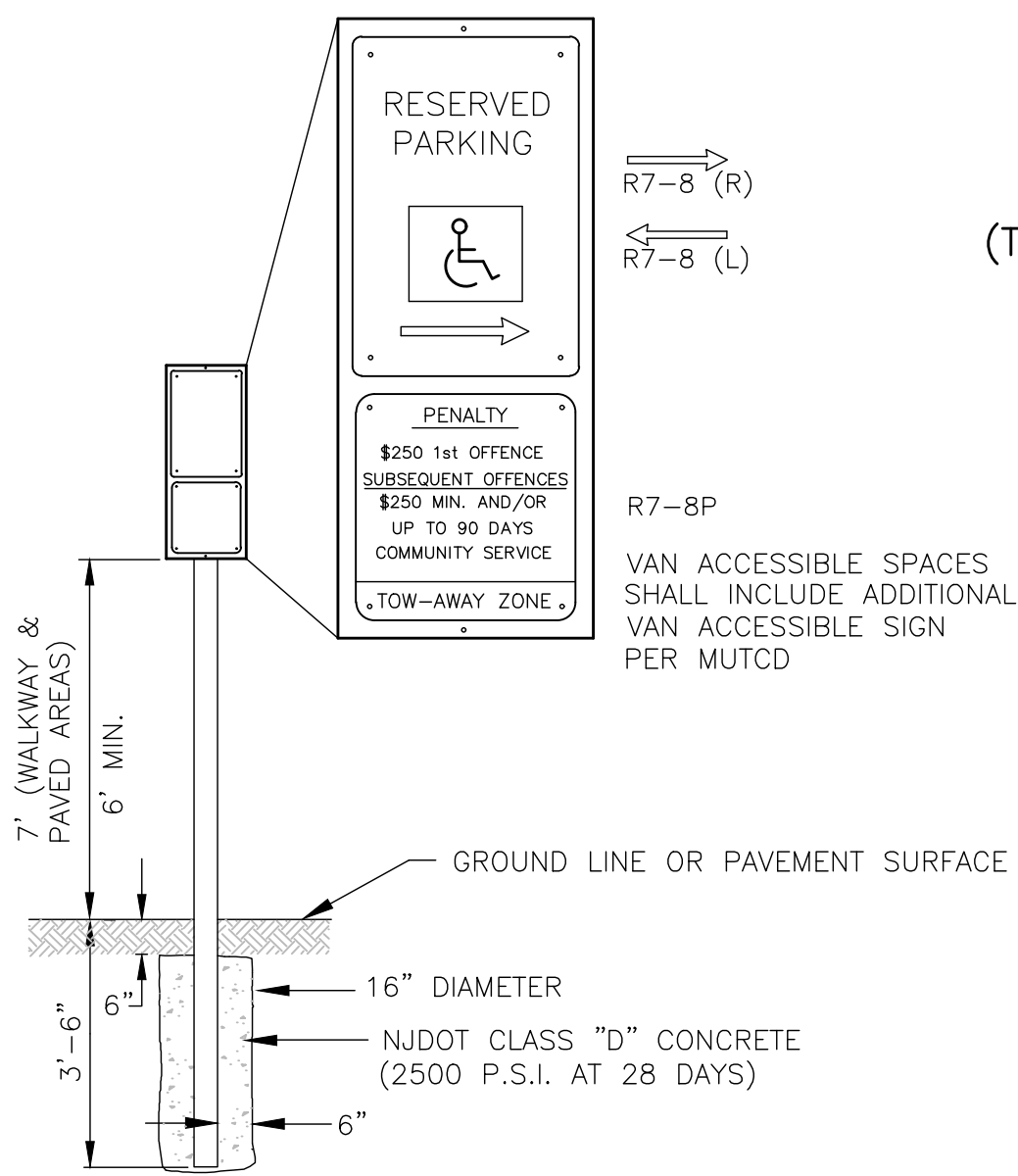

NOTE:
 ALL METAL SURFACES TO HAVE WEATHER PROTECTION FINISHES.

HANDICAP PARKING SIGN
 NOT TO SCALE

EXISTING GRASS (TO BE RESEED AS NECESSARY)

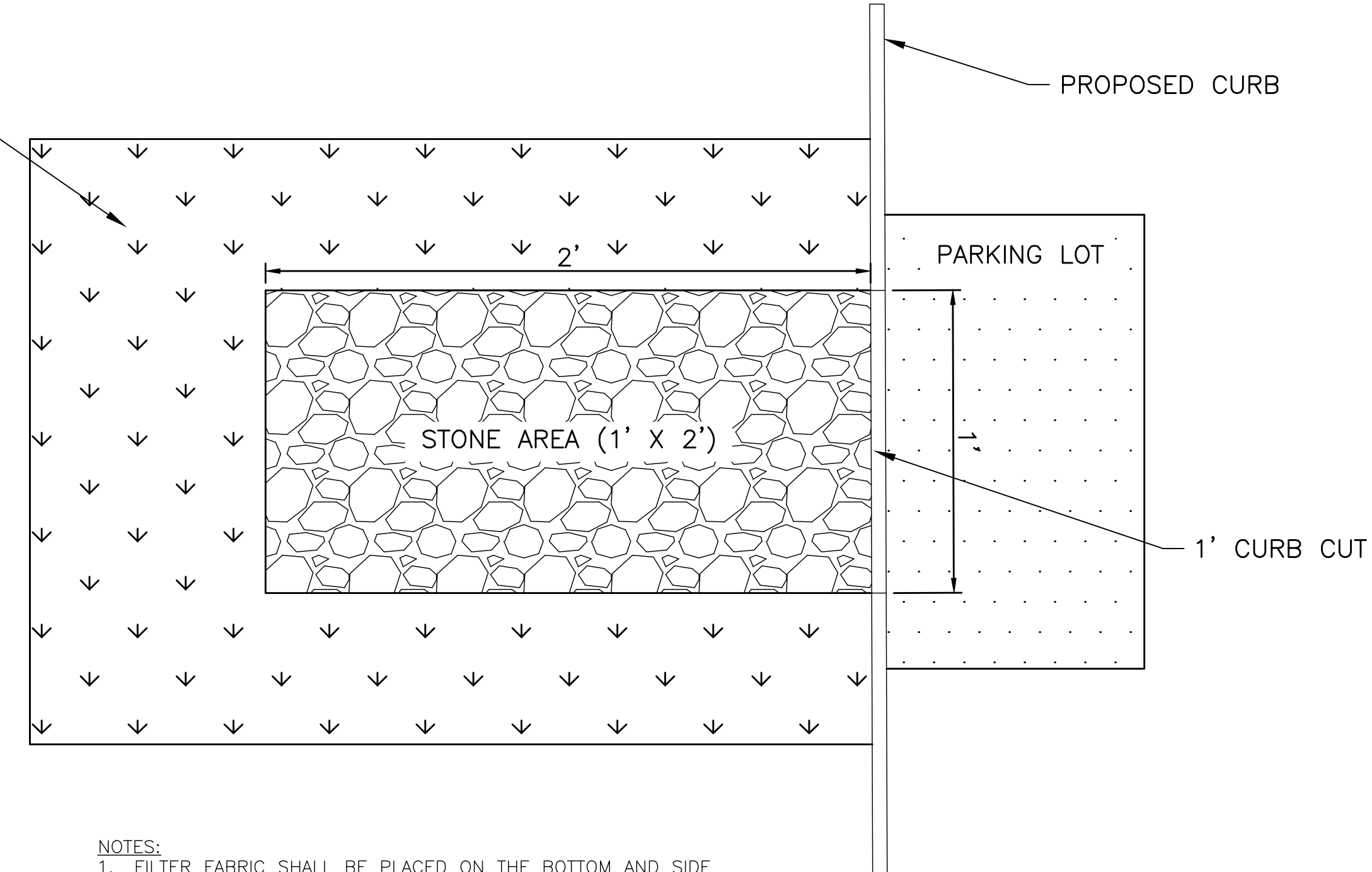

NOTES:
 1. FILTER FABRIC SHALL BE PLACED ON THE BOTTOM AND SIDE OF RIVER STONE, NO SEPARATE PAYMENT SHALL BE MADE.

CURB CUT PLAN VIEW
 NOT TO SCALE

PROJECT INFORMATION: T&M ASSOCIATES, INC. 100250\Plans\2022\03\02\2022\CONSTRUCTION PLAN.dwg
 FILE PATH: G:\Projects\100250\Plans\2022\03\02\2022\CONSTRUCTION PLAN.dwg
 FILE NAME: PISC-00250-CONSTRUCTION PLAN.dwg
 PLOTTED: 3/10/2022 12:20PM
 LAST SAVE BY: F5698

COPYRIGHT 2022, T&M ASSOCIATES, INC. ALL RIGHTS RESERVED. THE COPYING OR REUSE OF THIS DOCUMENT OR PORTIONS THEREOF, FOR OTHER THAN THE ORIGINAL PROJECT PURPOSES, IS EXPRESSLY INTENDED, WITHOUT THE WRITTEN PERMISSION OF T&M ASSOCIATES, INC. IS PROHIBITED.

NO.	DATE	REVISIONS	BY
2	3/21/2022	ADDENDUM #1	FS
1	3/10/2022	ISSUED FOR BID	FS
			PB
			CHD

PETER F. BONDAR, P.E.
 CONSULTING ENGINEER

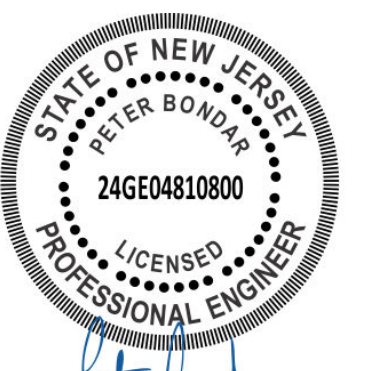

This item has been electronically signed and sealed by Peter Bondar, PE using a Digital Signature and date. Printed copies of this document are not considered signed and sealed and the signature must be verified on any electronic copies.

3/10/2022
 LICENSED PROFESSIONAL ENGINEER
 STATE OF NJ LICENSE NO. GE48108

TOWNSHIP OF PISCATAWAY
2022 - STERLING VILLAGE PARKING LOT REHABILITATION
 TOWNSHIP OF PISCATAWAY, MIDDLESEX COUNTY, NEW JERSEY
CONSTRUCTION DETAILS



11 TINDALL ROAD
 MIDDLETOWN, NJ 07748
 TEL 732-671-6400
 FAX 732-671-7365

DESIGNED BY	FS	DRAWING	CSD-1
CHECKED BY	PB	SHEET	4
DRAWN BY	FS	PROJ. NO.	PISC00250
DATE	3/10/2022	OF	9
SCALE	N.T.S.		

BID PROPOSAL FORM

BID FOR: 2022 - STERLING VILLAGE PARKING LOT REHABILITATION

**TO: MAYOR & TOWNSHIP COUNCIL
 TOWNSHIP OF PISCATAWAY
 455 HOES LANE
 PISCATAWAY, NJ 08854**

DATE: MARCH 31, 2022

TIME: 2:00 P.M.

STATEMENT OF FACT: The undersigned hereby declares that they have carefully examined the Bidding Documents, Plans, Specifications and addenda issued for the referenced project and have become familiar with all existing conditions affecting proper execution of the work and further offers to furnish all plant, labor, materials, supplies, management, supervision, and equipment and other facilities and things necessary or proper for or incidental to the **2022 - STERLING VILLAGE PHASE PARKING LOT REHABILITATION** for the following amounts:

BASE BID Tabulation

ITEM NO.	APPROX QUANT.	BID ITEM DESCRIPTION & WRITTEN BID AMOUNT	UNIT PRICE		ITEM TOTAL	
			DOLLARS	CENTS	DOLLARS	CENTS
1.	1 Lump Sum	Base Bid Amount _____	N/A	N/A	\$	
		Lump Sum Written in Words				
2.	2,000 Square Yards	Allowance #1 – 6” DGA Base Course _____	\$		\$	
		Unit Price Written in Words				
3.	2,000 Square Yards	Allowance #2 – 4” HMA Base Course _____	\$		\$	
		Unit Price Written in Words				
4.	1 Lump Sum	Allowance #3 – Planting Replacement Fifteen Thousand _____	N/A	N/A	\$	15,000 00
		Lump Sum Written in Words				
5.	1 Lump Sum	Allowance #4 – Existing Equipment Fifty Thousand _____	N/A	N/A	\$	50,000 00
		Lump Sum Written in Words				

Township of Piscataway
 2022 - Sterling Village Parking Lot Rehabilitation – Addendum #1
 Piscataway, NJ

ITEM NO.	APPROX QUANT.	BID ITEM DESCRIPTION & WRITTEN BID AMOUNT	UNIT PRICE		ITEM TOTAL	
			DOLLARS	CENTS	DOLLARS	CENTS
6.	1 Lump Sum	Allowance #5 –Asphalt Price Adjustment (Addendum #1) <u>Four Thousand</u> . Lump Sum Written in Words	N/A	N/A	\$ 4,000	00
*TOTAL AMOUNT BASE BID					\$	

*TOTAL AMOUNT BASE BID WRITTEN IN WORDS: _____

Tabulated Total Amount Bid **MUST agree with Total Amount Bid Written in Words.*

ADD ALTERNATE BID#1

ITEM NO.	APPROX QUANT.	BID ITEM DESCRIPTION & WRITTEN BID AMOUNT	UNIT PRICE		ITEM TOTAL	
			DOLLARS	CENTS	DOLLARS	CENTS
AA1.	1 Lump Sum	Granite Block Curbs I.L.O. Concrete _____ Lump Sum Written in Words	N/A	N/A	\$	
*TOTAL AMOUNT ALTERNATE BID					\$	

*TOTAL AMOUNT ALTERNATE BID WRITTEN IN WORDS: _____

Tabulated Total Amount Bid **MUST agree with Total Amount Bid Written in Words.*

The Owner reserves the right to reject all bids/proposals in accordance with N.J.S.A. 40A:11-13.2 and to waive any non-material informalities in the bidding. The Bidder agrees that his bid proposal may not be withdrawn for a period of SIXTY (60) days from the opening thereof except in accordance with N.J.S.A. 40A:11-23.3.

Conditional bid proposals will not be accepted. Bid Proposal Forms will not be accepted unless signed by the Owner or authorized Officer.

The Undersigned agrees, if awarded the Contract, to execute and deliver the Contract Agreement to the Owner within the timeframe specified in the Instructions to Bidders.

CERTIFICATION

The undersigned hereby affirms that they have carefully examined the Bidding Documents, Plans, Specifications and addenda issued for the referenced project and have become familiar with all existing conditions affecting proper execution of the work and the amounts bid herein represent the total cost for all work involved in the respective items and includes all plant, labor, materials, supplies, management, supervision, and equipment and other facilities and things necessary or proper for or incidental to the respective items, in accordance with the requirements of the Contract Documents.

_____	_____
Signature	Name & Title (type or print)
_____	_____
Bid Date	Name of Bidder
Company FEIN # _____	

Notarization Section

Subscribed and sworn before me this _____ day of _____ 20____.

Notary Public of _____

My Commission Expires _____



If a Corporation:

State of Incorporation: _____

